

SCALE 1:2

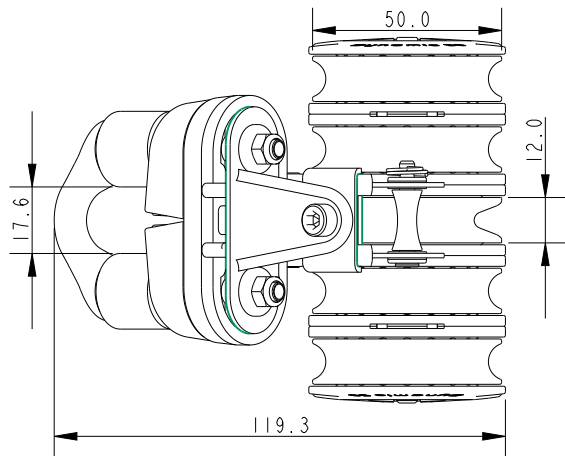

25° of Adjustment
with 3 positions at
12.5° intervals

DIMENSIONS FOR REFERENCE ONLY
allenbrothers.co.uk
 +44(0)1621 772477

Specification

Length mm	Line Diameter mm	Shackle Pin mm	Breaking Load kg	MWL kg	Weight g	Bearing Detail
123.05	8	5	950	470	503	Stainless steel

Title	Description
A2159-REF	Quint With Ratchet And Adjustable Cleat